

Multisystem - Indoor units

Double Flow Console



KID-06 S
Standard

Technical documentation	Download
User Manual	PDF
Controller Manual	PDF
Declaration of Conformity	PDF
Installation diagrams	PDF

Model		KSD-26 DR14-2	KSD-35 DR14-2	KSD-52 DR14-2
Cooling capacity rated	kW	2.6	3.52	5
Heating capacity rated	kW	2.9	3.81	5.28
Communication wiring	mm ²	(3+T)x2,5	(3+T)x2,5	(3+T)x2,5
Width / Height / Depth	mm	794 / 621 / 200	794 / 621 / 200	794 / 621 / 200
Net weight	kg	14.9	14.9	14.9
Air flow low / medium / high	m ³ /h	400 / 510 / 600	490 / 580 / 650	600 / 690 / 780
Sound pressure	dB(A)	27 / 34 / 36	27 / 34 / 37	32 / 38 / 41
Sound power level	dB(A)	50	54	55
Liquid / Gas pipe diameter	inch	1/4" / 3/8"	1/4" / 3/8"	1/4" / 1/2"

See compatibility of controllers in the range 1x1

Cooling and heating capacity: The energy coefficients are calculated under standard conditions. The actual operation conditions depend on the place in which the equipment has been installed and the use made of it.

Sound pressure: Measurement of the sound pressure is taken using an anechoic chamber at a distance of 1 m from the machine.

Communication wiring: The supply to the unit is made via communication wire.

NOTE: Before installing these units, current legislation regarding refrigerant gases must be consulted.

Multisystem - Indoor units

Double Flow Console

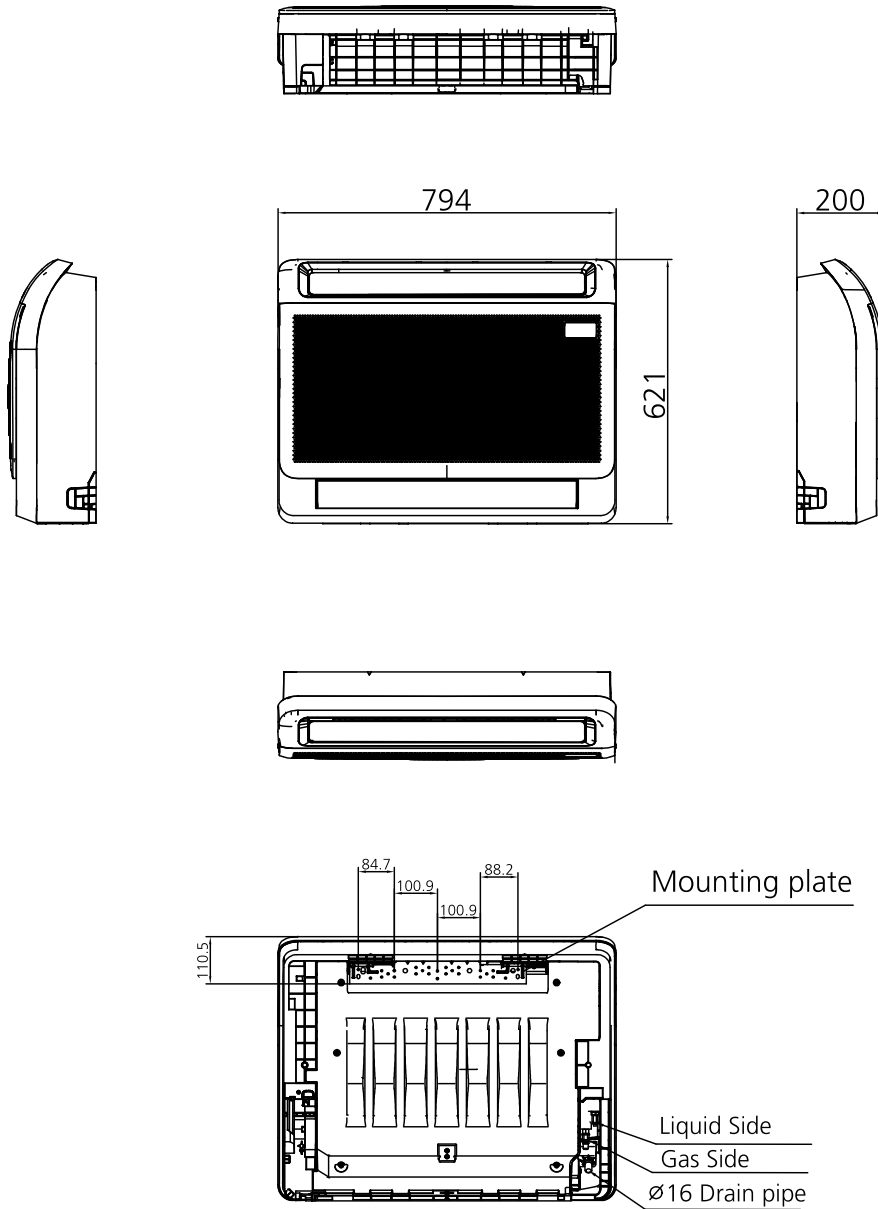

Multisystem - Outdoor units

Double Flow Console



Technical documentation	Download
User Manual	
Declaration of Conformity	
Dimensions	
Installation diagrams	



Model		KAM2-42 DR8	KAM2-52 DR8	KAM3-52 DR8	KAM3-62 DR8	KAM3-78 DR8	KAM4-80 DR7	KAM4-105 DR7	KAM5-120 DR8	
> Set										
Cooling capacity rated	kW	4.10	5.28	5.28	6.15	7.91	8.20	10.55	12.31	
Heating capacity rated	kW	4.39	5.57	5.57	6.59	8.21	8.79	11.14	12.6	
Heating capacity rated at -7°C	kW	3.5	3.62	3.7	4.13	6.52	5.81	7.33	8.54	
Cooling input rated	W	1270	1630	1450	1900	2450	2261	3265	3800	
Heating input rated	W	1200	1500	1380	1770	2200	2160	2840	3300	
Heating input rated at -7°C	W	1620	1490	1455	1750	3080	1875	4010	4077	
COP at -7°C		3.19	3.2	2.6	3.1	3.13	3.1	3.11	2.1	
SEER		6.8 - A++	6.6 - A++	6.8 - A++	6.5 - A++	6.7 - A++	7.2 - A++	6.5 - A++	6.5 - A++	
Communication wiring	mm ²	(3+T)x1,5	(3+T)x1,5	(3+T)x2,5	(3+T)x2,5	(3+T)x2,5	(3+T)x2,5	(3+T)x2,5	(3+T)x2,5	
No. indoor units		2	2	3	3	3	4	4	5	
Power supply	V/ph/Hz	220-240/1/50	220-240/1/50	220-240/1/50	220-240/1/50	220-240/1/50	220-240/1/50	220-240/1/50	220-240/1/50	
Power wiring	mm ²	(2+T)x2,5	(2+T)x2,5	(2+T)x4	(2+T)x4	(2+T)x4	(2+T)x4	(2+T)x6	(2+T)x6	
Width / Height / Depth	mm	805 / 554 / 330	805 / 554 / 330	805 / 554 / 330	890 / 673 / 342	890 / 673 / 342	946 / 810 / 410	946 / 810 / 410	946 / 810 / 410	
Net weight	kg	31.6	35.5	36.2	46.8	53	64.3	68.8	74.10	
Air flow	m ³ /h	2200	2200	2100	3000	2700	4000	4000	3850	
Sound pressure	dB(A)	57	56	57	57.5	54	61	63	61.5	
Sound power level	dB(A)	66	63	64	66	67	69	68	70	
> Refrigerant										
Type refrigerant		R-32	R-32	R-32	R-32	R-32	R-32	R-32	R-32	
GWP		675	675	675	675	675	675	675	675	
Refrigerant charge	kg	0.9	1.25	1.5	1.4	1.72	1.8	2.1	2.9	
t CO ₂ eq	tCO ₂	0.61	0.84	1.01	0.95	1.16	1.22	1.42	1.96	
Liquid / Gas pipe diameter	inch	2x 1/4" / 2x 3/8"	2x 1/4" / 2x 3/8"	3x 1/4" / 3x 3/8"	3x 1/4" / 3x 3/8"	3x 1/4" / 3x 3/8"	4x 1/4" / 3x 3/8" + 1x 1/2"	4x 1/4" / 3x 3/8" + 1x 1/2"	5x 1/4" / 4x 3/8" + 1x 1/2"	
Piping total length	m	40	40	60	60	60	80	80	80	
Vertical piping max. length	m	15	15	15	15	15	15	15	15	
> Working range										
Outdoor ambient temperature for heating min. / max.	°C	-15 / 24	-15 / 24	-15 / 24	-15 / 24	-15 / 24	-15 / 24	-15 / 24	-15 / 24	
Outdoor ambient temperature for cooling min. / max.	°C	-15 / 50	-15 / 50	-15 / 50	-15 / 50	-15 / 50	-15 / 50	-15 / 50	-15 / 50	

Cooling and heating capacity. Cooling and heating input. Energy efficiency: The energy coefficients are calculated under standard conditions. The actual operation conditions depend on the place in which the equipment has been installed and the use made of it.

Sound pressure: Measurement of the sound pressure is taken using an anechoic chamber at a distance of 1 m from the machine.

Power wiring: The power wiring is up to 10 m approximately. It must be calculated more precisely for each installation.

Supplementary charge: The initial charging of the outdoor machines is valid for the first 7.5 m (liquid line). A supplementary charge of 0.012 kg/m is required for greater distances per each additional metre.

NOTE: Before installing these units, current legislation regarding refrigerant gases must be consulted.

Multisystem - Outdoor units

Double Flow Console

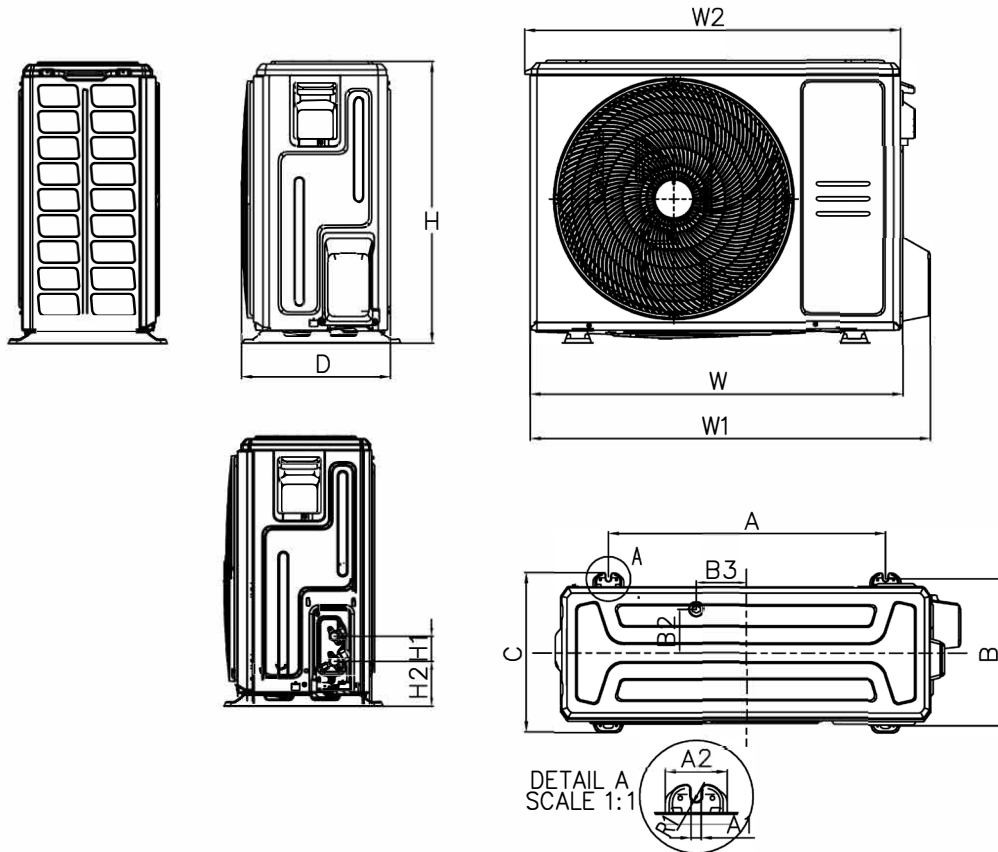

Platform	W	W1	W2	D	H	A	B	C	H1	H2	A1	A2	R1	B2	B3
X1	720	790	727	270	495	452	255	281	60	87	11.7	49	6	76.5	33
X2	765	835	784	303	555	452	286	314	60	93	10	62	5	76	18
X3	805	874	815	330	554	511	317	346	60	95	10	58	6.5	105	49
X4	890	955	895	342	673	663	354	380	60	108	12	74	6	52	61
X6	980	1073	/	415	975	616	397	440	60	114	12	76	6	111	95
D	946	1030	/	410	810	673	403	455	60	108	24	73	6	95	10

ODU	
KAM2-42 DR8	X3
KAM2-52 DR8	
KAM3-52 DR8	
KAM3-62 DR8	X4
KAM3-78 DR8	
KAM4-80 DR7	D
KAM4-105 DR7	
KAM5-120 DR8	